



The content is published under Creative Commons Attribution 4.0 International license (CC BY 4.0).

Reviewed Article:

Reconstruction of the Geometric Décor Technology of the Bronze Age Ceramics in Siberia

Persistent Identifier: <https://exarc.net/ark:/88735/10273>

EXARC Journal Issue 2017/1 | Publication Date: 2017-02-15

Author(s): Eva Lamina ¹ ✉

¹ Independent researcher, address withheld by the editors (GDPR), USA.



The grassland and forest steppes ranging from the Ural to the Altai-Sayan mountains were dominated by Andronovo Family cultures during the second millennium BC (the Bronze Age) (Koryakova & Epimakhov 2007; Мартынов 2005). The Andronovo dated ceramic series were characterized by a distinctly expressed geometric ornamentation style.



It is improbable that a highly developed counting or measuring system (similar to metric system) existed in the steppe and forest-steppe regions of Siberia during the Bronze Age. Nevertheless the Andronovo population was capable of creating reproducible and stereotyped geometrical décors.

Numerous studies have described Andronovo ceramics and its typical ornamental features. However, among those publications, very few authors discuss the technical aspects of how the Andronovo geometric designs were created (Бобров& Михайлов1989; Зотова1965; Кожин2012; Кузьмина1986; Рудковский2013).

It should be noted that the current authors were influenced by studies of the ornaments' morphology developed by ethnographer S. V. Ivanov (1963) more than 50 years ago and based on Northern Asian material culture. In particular, Ivanov (*ibid*) suggested considering varieties of ornamentation by grouping them in several categories including net pattern category, or "symbol" in Ivanov's terminology.

In archaeological publications, the net pattern was considered not only a means of morphological classification of the ornaments, but also, it has been assumed, a common

technique used in manufacturing of the Andronovo geometric decors (Зотова1965; Кожин2012; Кузьмина1986; Рудковский2013).

According to Ivanov, "... the most simple ornaments require compliance with certain conditions ...in creating an ornament, the person ...should be guided by a feeling of measure, order, and calculation" (Иванов1963, 7). This remark naturally raises more general questions, which lie beyond limits of the Andronovo geometric style ceramics.

One view posits that the Andronovo geometrical ornament could be considered a product of a pure art, and based on specific personal skills of the artist possessing knowledge of certain learned patterns (Рудковский2013). However, the similarity of ornaments found across wide territorial ranges and chronological frames may indicate the possibility that they were manufactured using technologies that provided reproducibility and comparative consistency of patterns.

The objective of the present study is to explore potential methodology which could explain how the Andronovo potters managed to consistently create such complex geometrical ornaments.

Geometrical décor and counting skills

Ethnographic research studies have shown the possible existence of vestiges of advanced ancient counting methods used among Siberian people. These were important to their comprehension of the world, in the order of social events, and in mythology; for example,

recorded accounts of legendary ancestors, spirits, levels of the top world, number of magic ways of shaman, as well as more prosaic concerns such as numbers of children and cattle (Алексеев1984; Golovnev 1994).

Among the few ethnographic sources concerning counting skills in an ordinary individual's life of the native population, there are interesting observations dated to the beginning of the 20th century in the Taiga region of the Far East (Арсеньев2007). According to Arseniev (Арсеньев2007), Taiga hunters practicing their indigenous lifestyle used atypical counting skills in craft practices - especially evident in female needlework - to assess time and distance, spatial orientation, and distribution of hunting trophies. It was also noted that even following cultural assimilation, the local population continued to use a certain set of native words that always included ancient designation of numbers (Арсеньев2007).

Reconstructions of counting systems based on archaeological evidence deserves more attention. Investigators in this specific area are frequently discussing questions of the origin of counting methods, development of calendar systems, methodical approaches to produce geometrical ornaments and so on (Иванов1963; Кожин2012; Ларичев1989; Шер, Вишняцкий& Бледнова2004).

Geometric designs are one of the most interesting and attractive topics on that subject. Research reports emphasized that certain geometrical decors are universal and widely spread. Well preserved artefacts with such decors can be found in archeological sites dating from the Upper Paleolithic through to the Iron Age (Иванов1963). Even after setting aside their resilient conservation in time and space, or how and why they remained essentially unchanged throughout centuries and generations, the question remains as to how these geometric designs were created in the first place.

With regards to the ceramic ornamentation, there are questions as to the type of measuring tools used and the counting system employed. There are a limited number of variables applied in the crafting of a particular ceramic vessel: for example, the height of the walls, the diameter, and the perimeter of a horizontal section (See Figure 1). It is possible to hypothesize that this ancient decorative technique can be reconstructed based on application of the formalized image of the spiral in one and a half turns as a basic tool (see also Lamina 2008).

On the plan of the spiral in one and a half turns, there could appear to be a square each side of which includes three parts. In terms of the area, two-thirds of the square equals one turn of the spiral (a conditional circumference), therefore the next third appears in the subsequent turn (See Figure 2a).

The diagonal which is passing through the center of the spiral pattern consists of six parts (See Figure 2b), whereas practically the diameter of the section may be presented

conveniently with eight parts (See Figure 2b). The graphic extension of sides of the pattern on the plan up to twelve parts shows that the actual diameter is now possible to present as one consisting of ten parts (See Figure 2b). The consecutive proportional extension of the initial diameter (D8) can be done in three steps: (1) an increase of initial diameter up to ten parts (D10), (2) return the value back to eight parts; and (3) an extension of diagonal up to ten parts again (D12) (See Figure 2c). The resulting length (12.5 parts of initial diameter) with an insignificant error is equal to half of perimeter of the horizontal section (See Figure 2e), whereas potentially the perimeter can be estimated as consisting of 100 parts.

By twisting half of the perimeter in a spiral in the opposite direction, it is possible to determine the size of diameter pertaining to the length of a related circle and this can be done in two steps: (1) reduction of length on one eighth part, and (2) reduction on a quarter length of the following one eighth part. Three of the four remaining parts would be equal to initial diameter (See Figure 2d). Accordingly, the ratio of diameter to half of perimeter may occur with an admissible error is certain as five eighths or two thirds (See Figure 2d).

In the published literature ornaments which feature geometrically precise spiral patterns may be dated to as early as the Neolithic period. According to some observations, these spiral motifs were united in more complex and elaborated decors, and are placed into a certain zone or are settled down around a common center (or point) (Титов1969). Taking this into account, it is possible to consider the overall design as consisting of the sum of four non-overlapping three-fold patterns situated around a central point (See Figure 3a).

In such cases, the estimation of the perimeter of the horizontal section can be based only on the graphic plan (and the corresponding parts and proportions), and therefore does not require calculations. Instead it involves the reduction of the diameter in proportion with size of the three-fold pattern (one and a half turns of the spiral) (See Figure 3b).

Unless one is an expert, it would be quite difficult to explain how the length of a circle can be expressed with insignificant error through the linear sizes of three-fold pattern (six parts) and a central part (half) (See Figure 3a). Nevertheless, the given piece divides circle length at least in ten at most into sixty parts depending on the chosen unit of measure (accordingly two and a half and fifteen parts for each quarter of perimeter) (See Figure 3c).

If the value of six and a half automatically divides the perimeter of the cross section of the vessel into a minimum of five parts, then it is possible to assume that the ratio of diameter and relevant length of the circle could be represented on the plan. In particular, the initial scheme can be converted into the one based on even numbers. More specifically, it can be represented by the parts related to the circle and occupying two thirds of the area of the spiral pattern (See Figure 4a).

In the case when the diagonal of each conditional subsequent square (three-fold pattern) is at the same time the side of the previous one, it is possible to consider the ratio of diameter to perimeter in the terms of area. Two graphical variants may be suggested for this association (See Figure 4b, c). In both cases the pattern splits into two branches (the diagonal and the adjacent side), but the difference is in the direction of movement of the pattern. In the first case the circular direction dominates (See Figure 4b), and in the second the pattern moves forward, thus forming a smaller common area with the previous and the next conditional element (See Figure 4c). The areas of the squares form a certain geometric sequence with a step of two, regardless of changes in the magnitude of the diagonal side. Though the proportional relationship may not be obvious, however the relationship can be determined graphically using shading. The hatched area may represent a possible method for conducting such calculations.

In this regard we can cite the formal similarity of the proposed scheme with archaeological materials. One such example is the decorative “pyramid”, which was widespread in the Eurasian cultures of the Bronze Age. This “pyramid” motif was a triangular chart with a base consisting of two to eight units. According to the ethnographic data, for example the counting system of the Khanty (an aboriginal people of Siberia) was limited to seven (Golovnev 1994). If we consider this motif of décor as a kind of primitive counting device, the manipulations of values below the third or fourth lines in the triangle chart with a larger base would be beyond comprehension, according to their culture. On the other hand, it cannot be excluded that in conditions of calculating in a closed area, counting might not end at seven, but rather begin at seven.

Thus, the proposed formalized image of spiral (one and a half turns) has shown its utility not only as means of measuring, but also as a possible source of geometric decorative motifs. The pattern under review and the appropriate ratios can be transferred to the walls of a ceramic vessel. From this point of view it can be regarded as an art of ornamentation. However, in conditions where tools and pottery exhibit technical imperfections, the execution of geometrical decors on ceramics required certain skills and generalization of empirical knowledge.

Experimental reconstruction of Andronovo ornamental schemes

It is improbable that a highly developed counting or measuring system (similar to metric system) existed in the steppe and forest-steppe regions of Siberia during the Bronze Age. Nevertheless the Andronovo population was capable of creating reproducible and stereotyped geometrical décors. The formalized image of the spiral in one and a half turns is proposed as a measuring tool used to calculate the most appropriate proportional ratios.

The vessel from the Andronovo (Fedorovo) closed complex, from the Altai region and dated to 16th century BC, was chosen as a model for the reconstruction (Кирюшин, Тишкин&

Грушин2000, fig. 2) (See Figure 6a).

In the literature it was assumed that ornamentation could use some sort of preliminary sketches (Бобров& Михайлов1989). This hypothetical assumption can be quite real if the draft was executed for a part of the vessel's surface. As supplementary material to this, it is also possible to use the image of the "pyramid" pattern (triangle chart) that shows the area of the horizontal section and related perimeter; these may be estimated by different units and the smaller the partition the larger the virtual area.

Because all measurements according to the proposed technique are supposed to be executed for the quarter of the perimeter of the horizontal section of the vessel, the first task is to divide the surface of the vessel into four equal parts along the vertical axis.

As shown above, increasing the initial value of diameter (eight parts) up to twelve parts provides a way of estimating the corresponding perimeter. Increasing the value of the quarter of the perimeter up to ten parts and converting the length into even (four) number of parts (See Figure 5a) and provides some sort of scale that converts eight parts into another number of units. Thus, a quarter of the perimeter can be defined as consisting of approximately three one-quarter parts that will be in accordance with value of the meander décor of the sample under review.

The triangular diagram also shows that the quarter of the perimeter could be represented as two one-quarters and one one-quarter parts (See Figure 5b). Division could be in principle created, based on the fact that either parts of the triangular diagram are linked with each other. Thus, it moves along the diagram upwards from line five in the direction of diminishing values and line four could be represented as a value of three and a half (See Figure 5c). During movement in the opposite direction (toward increasing values) line six could be converted to six and a half (See Figure 5c). Using the obtained dimensions in place of D10, a quarter of perimeter could, correspondingly, be divided into two and a quarter and one and a quarter parts (See Figure 5d). However, the resulting values of such division of the perimeter do not correspond to the original.

Meander décor and triangle chart designs are intimately connected to each other in the ornamental schemes attributed to the Andronovo (Fedorovo) culture (Бобров& Михайлов1989). It can be assumed that the meander décor performed on the triangle net with center settled on the line six and a half may reduce the proportion of empiricism in measurements, providing relevant markers were used (See Figure 5e).

Those same measurements can be carried out using the formalized image of spiral one and a half turns as a tool. This is evident by the fact the spiral pattern represented in terms of area allows graphical representation of proportional ratios (two-thirds and five-eighths) between the diameter and relevant length of perimeter (See Figure 6b). This means that value which is

supposed to be used for measuring should satisfy those ratios; therefore, it should be folded into four parts. The same proportion may be used to describe ratio between horizontal (eight) and vertical (five; ten) dimensions of the ornamental field (See Figure 10a, b). Given that the pattern could be expressed either by even or odd numbers of composing units, the choice of the values for the further manipulations may be limited to the values spaced by two or two and a half steps (See Figure 6c).

Furthermore, the value that estimates the length of the quarter of the perimeter may be compared to the scale consisting of eight parts in terms of proportions that avoids the labyrinth like calculations. For example, comparing nine and a half (step 2.5) to the scale eight shows that approximately three and a quarter parts are corresponding to nine and three quarters (See Figure 6d). Respectively decreasing the value by a quarter (up to 9.5) will increase the number of parts up to six and three quarters. Thus quarter of perimeter of the vessel under review may be estimated in the conditional units as consisting of six and a half (one conditional part is equal to $9.75:4$) and six and three quarter (one conditional part is equal to $9.5:4$) (See Figure 6e). The meander design itself can be represented as consisting of squares and those areas were related to each other in proportion 1:2:4 (See Figure 6e). This technique could be applied to the ceramic décor of the Andronovo sites of the neighboring regions (Бобров& Михайлов1989, fig.19, 2; Молодин1985, fig. 46, 2) (See Figures 7, 8, 9).

Despite the conventions and limitations and floating scaling, the proposed technique based on the measurements of the quarter of the perimeter improves the overall accuracy of the separation of its length into the equal parts and together with the graphical designation of fractions gives sufficient space to create a wide range of ornamentation. The decor may be preliminary displayed graphically by means of proportions and conditional units (See Figures 6, 7, 8, 10b).

Conclusion

The experimental reconstruction of the technique supposedly used for the execution of the Andronovo ceramic geometrical décor has shown that it is unlikely that these designs could be executed without a specific knowledge of basic geometry and the employment of appropriate measuring tools.

The graphic formalized image of the spiral turn has been proposed as a basic estimating and measuring tool to reconstruct the Andronovo geometric décor.

The sequence of manipulations was explored, which allowed for the evaluation of the basic dimensions of a vessel (the diameter and the perimeter of the horizontal section) with the aid of a formalized image of a spiral.

There is a reason to believe that the same principle of execution of geometrical décor might be common amongst the Andronovo population.

On the other hand, taking into account the probable involvement of the local (pre-Andronovo) population in the formation of the Andronovo cultures, it can also be suggested that similar techniques may have existed before the Andronovo time, albeit in other ornamental configurations.

📖 Keywords **ceramics**
decoration

📖 Country **Russia**

Bibliography

GOLOVNEV A.V., (1994). From one to seven: numerical symbolism in Khanty culture. *Arctic Anthropology*, 31(1), pp.62-71.

KORYAKOVA L. and EPIMAKHOV A.V. (2007). *The Ural and Western Siberia in the Bronze and Iron Ages*. Cambridge: Cambridge University Press.

LAMINA E. (2008). Application of a set of avian bones for reproduction of prehistoric geometric designs. *EuroREA*, 5, pp.15-18.

АЛЕКСЕЕВ Н.А. (1984). *Шаманизм тюркоязычных народов Сибири*. Новосибирск: Наука.

АРСЕНЬЕВ В. К. (2007). *Дерсу Узала*. Собр. Соч., 1. Владивосток: Альманах "Рубеж".

БОБРОВ В. В. & МИХАЙЛОВ, Ю. И.(1989). *Памятники андроновской культуры Обь-Чулымского междуречья*. Кемерово: КемГУ.

ЗОТОВА С.В. (1965). Ковровые орнаменты андроновской керамики . *Материалы и исследования по археологии СССР*,130, с.177-181.

ИВАНОВ С.В. (1963). *Орнамент народов Сибири как исторический источник (по материалам XIX-начала XX в)*. Народы Севера и Дальнего Востока. Труды Института Этнографии им. Н. Н. Миклухо-Маклая, новая серия, 81. М.- Л.: Академия наук СССР.

КИРЮШИН Ю.Ф., ТИШКИН А.А. & ГРУШИН С.П. (2000). Андроновская могила на памятнике Телеутский Взвоз-1. *Актуальные вопросы истории Сибири*. Барнаул: АГУ, с.40-47.

КОЖИН П.М.(2012). Лепная керамика кочевников развитого бронзового века в Средней Азии. *Труды Маргианской археологической экспедиции, 4. Исследования Гонур Деле в 2008-2011 гг*. Москва: РАНИЭА, с.199-221.

КУЗЬМИНА Е.Е. (1986). Гончарное производство у племен андроновской культурной общности (об одном археологическом аспекте проблемы происхождения индоиранцев). *Восточный Туркестан и Средняя Азия в системе культур Древнего и Средневекового Востока*. М.: Наука, с. 152-182.

ЛАРИЧЕВ В. Е. (1989). *Мудрость змеи: первобытный человек, Луна и Солнце*. Новосибирск: Наука.

МАРТЫНОВ А. И. (2005). *Археология*. М.: Высшая школа.

МОЛОДИН В. И. (1985). *Бараба в эпоху бронзы*. Новосибирск: Наука.

РУДКОВСКИЙ И. В. (2013). *Андроновская орнаментика в контексте системообразующих инвариантов*. Алма-Аты: Институт Археологии А. Х. Маргулана.

ТИТОВ В. С. (1969). *Неолит Греции. Периодизация и хронология*. М.: Наука.

Шер Я. А., Вишняцкий Л. Б. & Бледнова Н. С. (2004). *Происхождение знакового поведения*. М.: Научный мир.

The Andronovo ceramics. <http://public.edu.asu.ru>, retrieved 01/05/2017

 Share This Page

| Corresponding Author

Eva Lamina

Independent researcher

Address withheld by the editors (GDPR)

USA

[E-mail Contact](#)

| Gallery Image

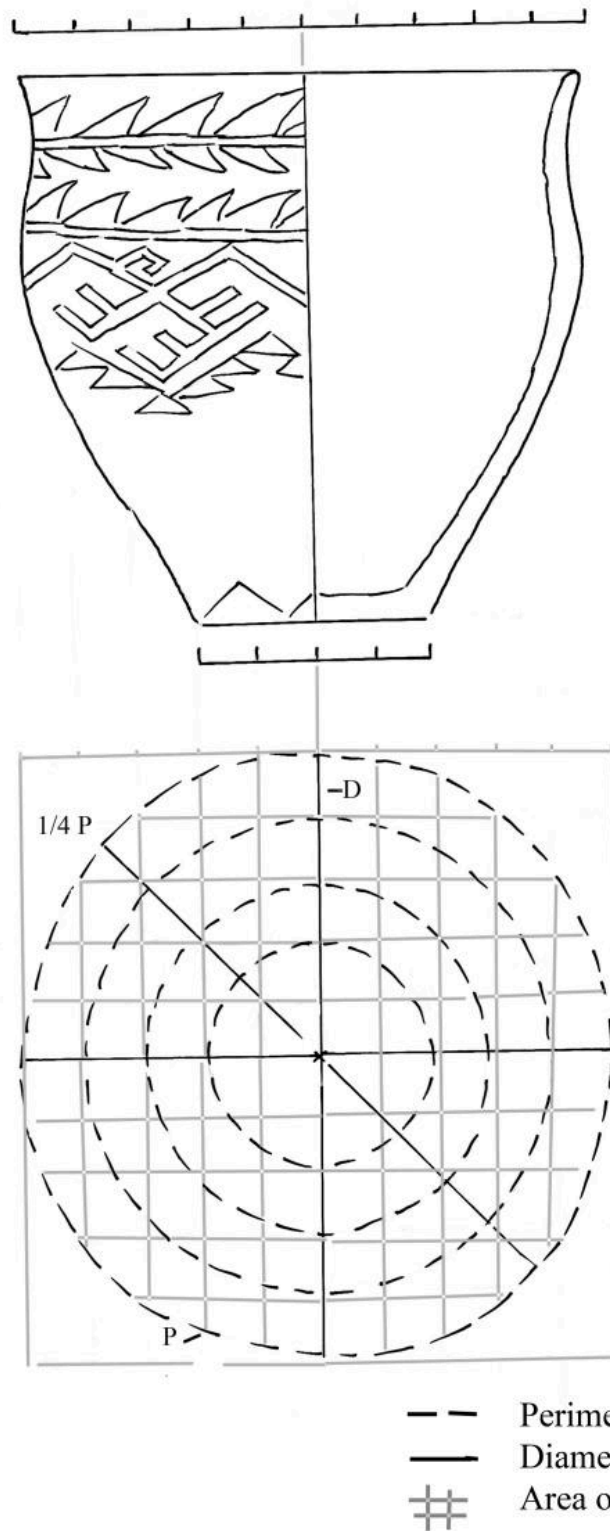

Figure 1. Schematic illustration for the used geometric terms
 (original from: Кирюшин, Тишкин & Грушин, 2000)

FIG 1. SCHEMATIC ILLUSTRATION FOR THE USED GEOMETRIC TERMS (ORIGINAL FROM: SEE IMAGE)

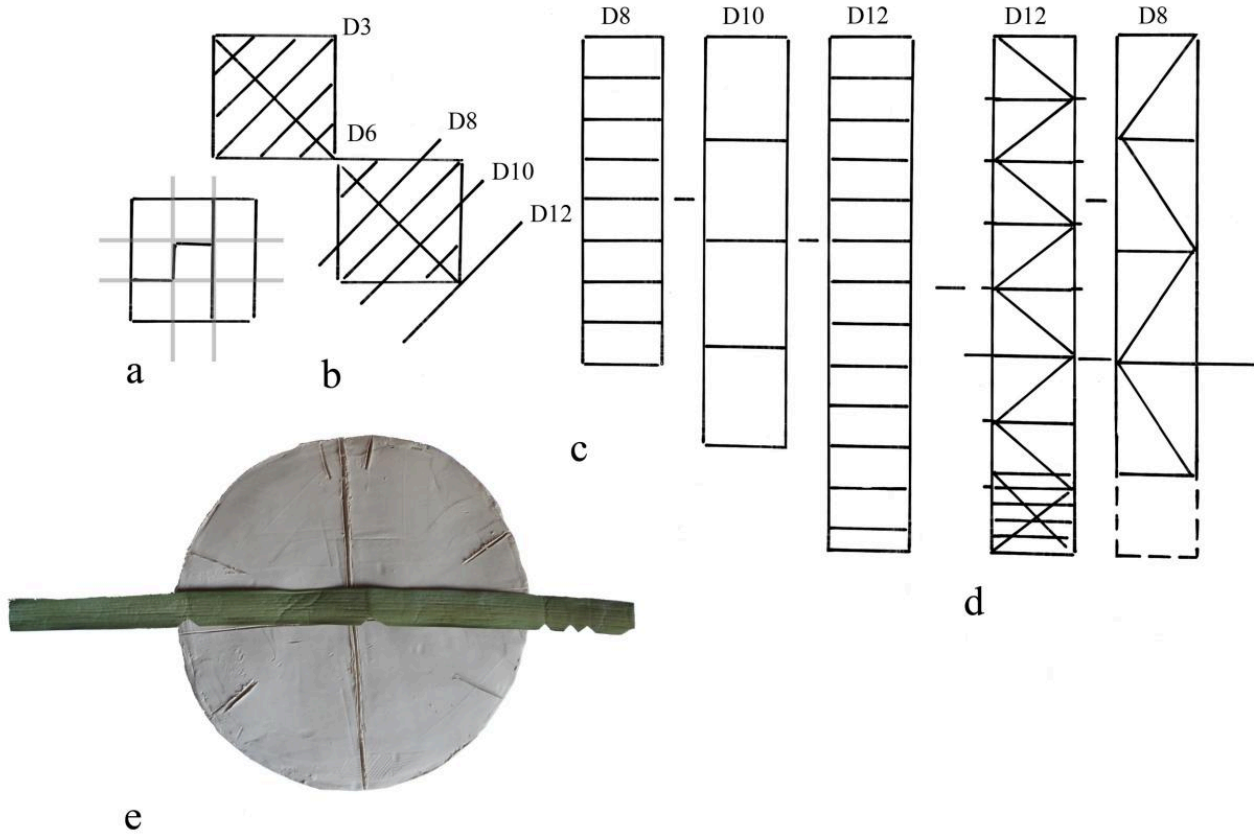

Figure 2. Estimation of diameter and perimeter of a horizontal section of a ceramic vessel using the spiral pattern.

FIG 2. ESTIMATION OF DIAMETER AND PERIMETER OF A HORIZONTAL SECTION OF A CERAMIC VESSEL USING THE SPIRAL PATTERN.

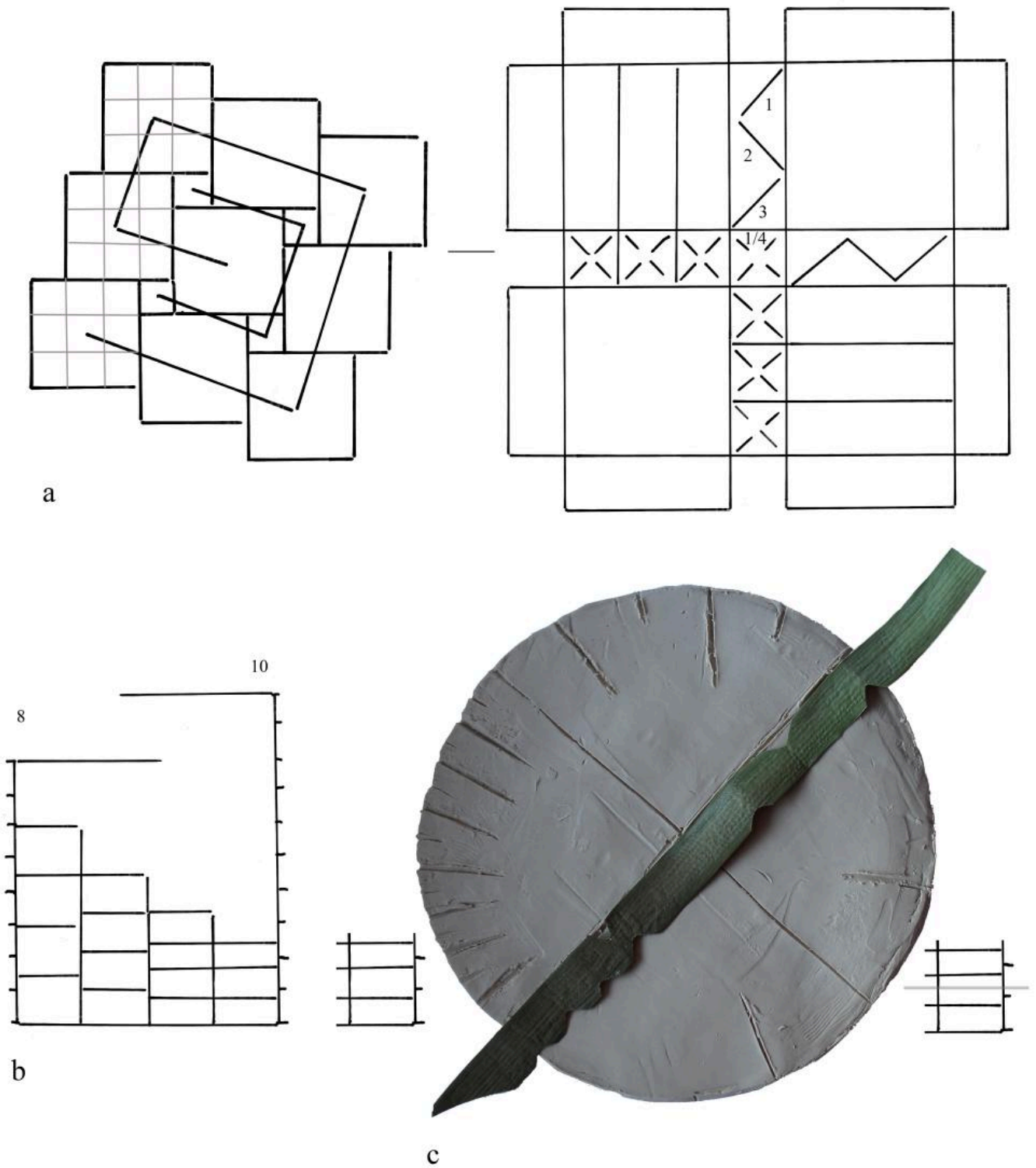
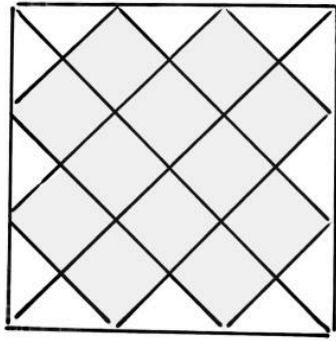
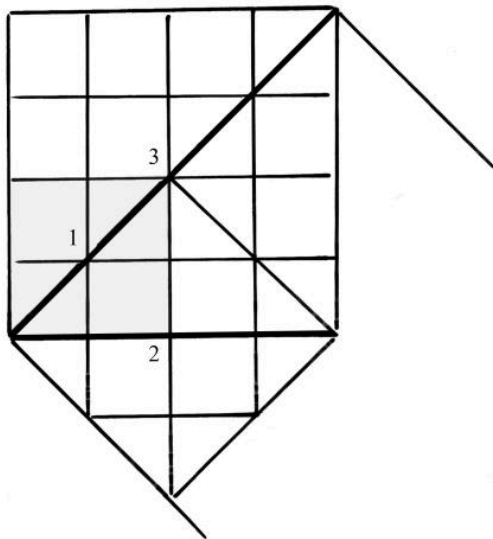
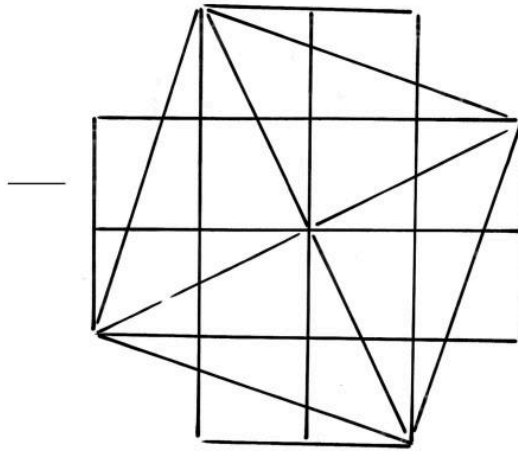

Figure 3. Estimation of perimeter of horizontal section using an organized net pattern.

FIG 3. ESTIMATION OF PERIMETER OF HORIZONTAL SECTION USING AN ORGANIZED NET PATTERN.



a



b

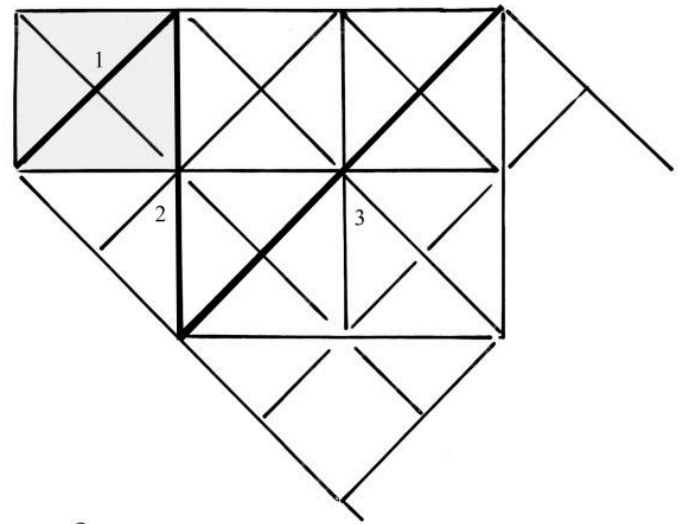

c

Figure 4. Estimation of relationship of diameter and perimeter expressed in terms of area.

FIG 4. ESTIMATION OF RELATIONSHIP OF DIAMETER AND PERIMETER EXPRESSED IN TERMS OF AREA.

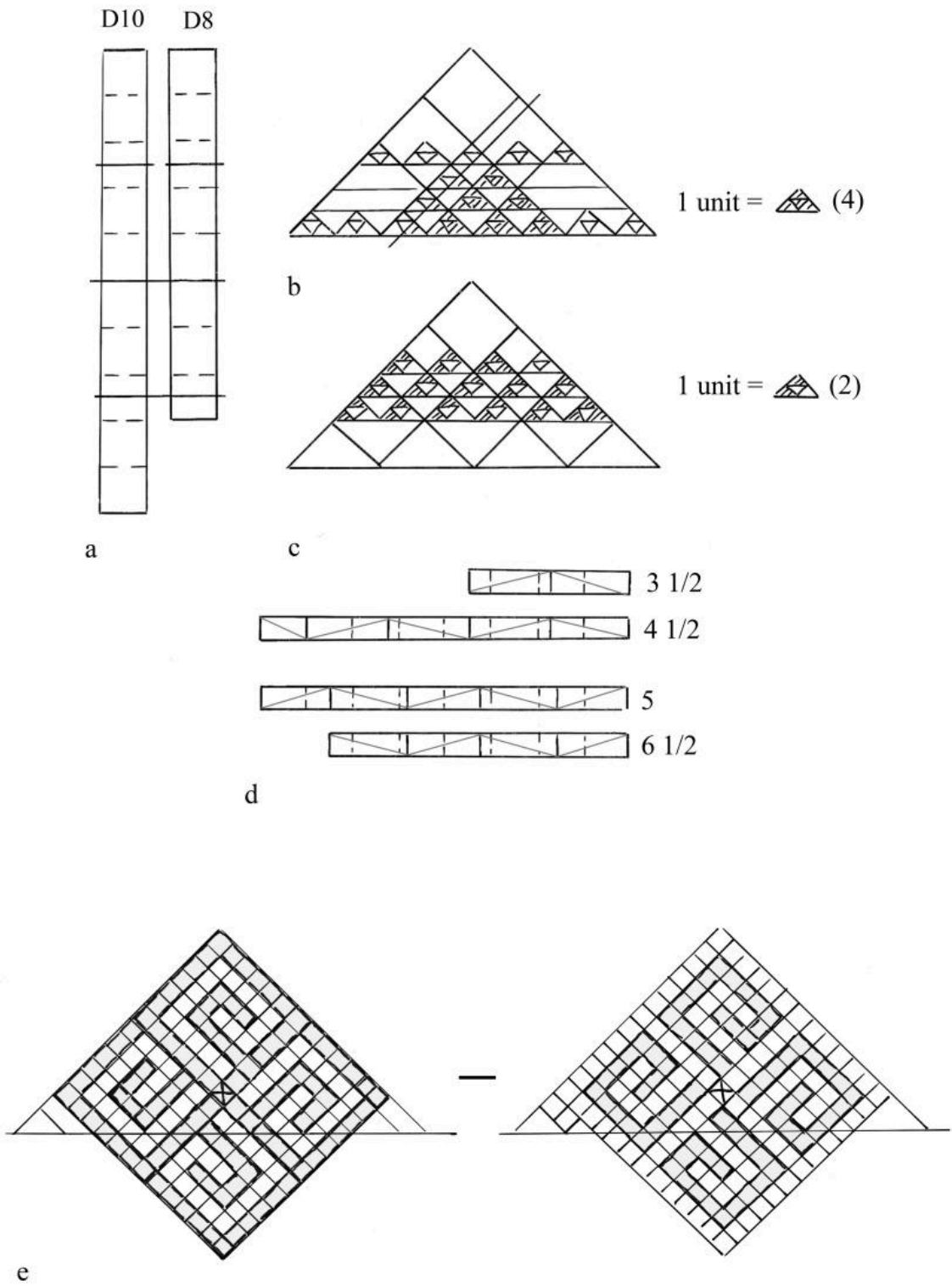

Figure 5. Application of triangle chart for estimation of perimeter of horizontal section.

FIG 5. APPLICATION OF TRIANGLE CHART FOR ESTIMATION OF PERIMETER OF HORIZONTAL SECTION.

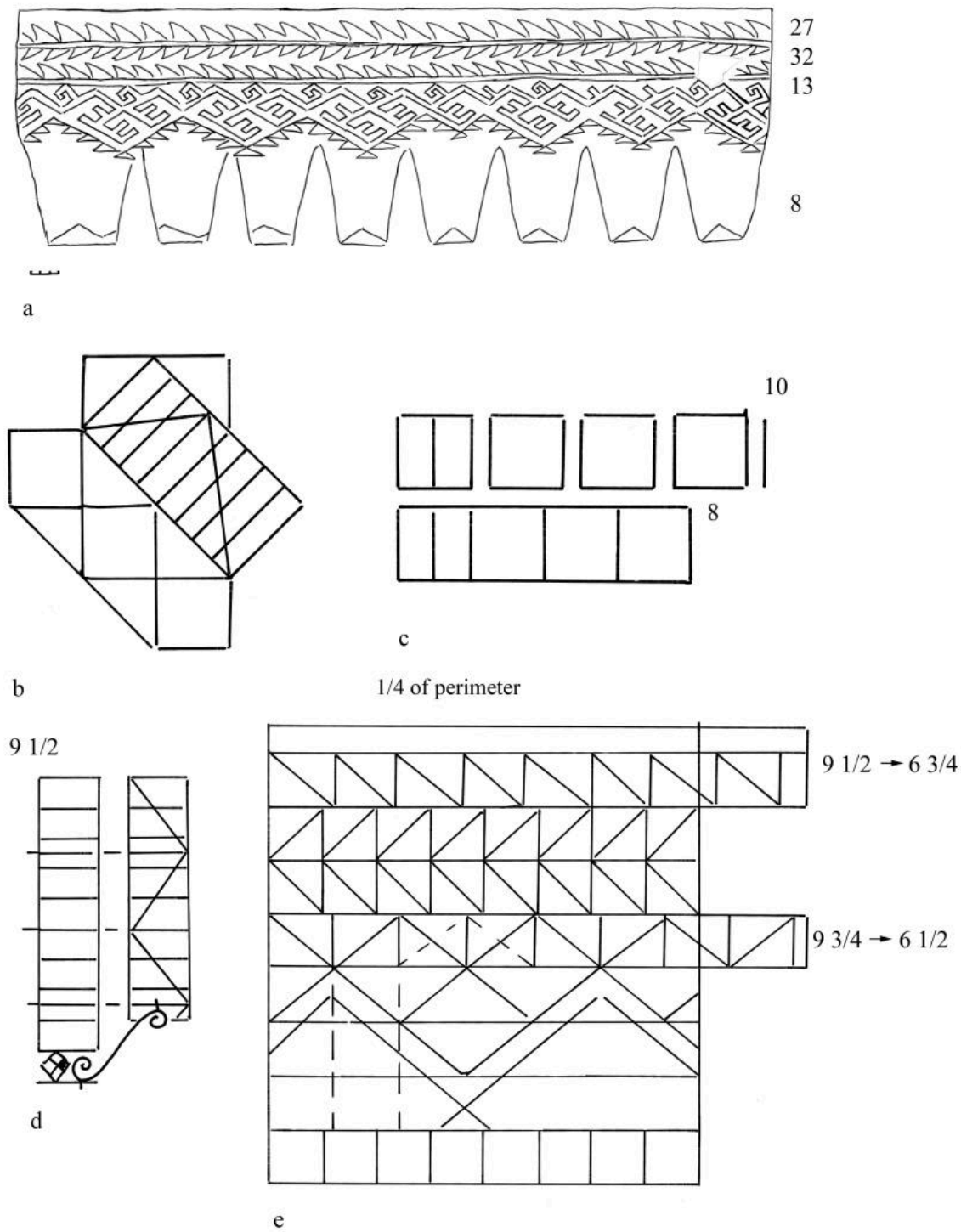
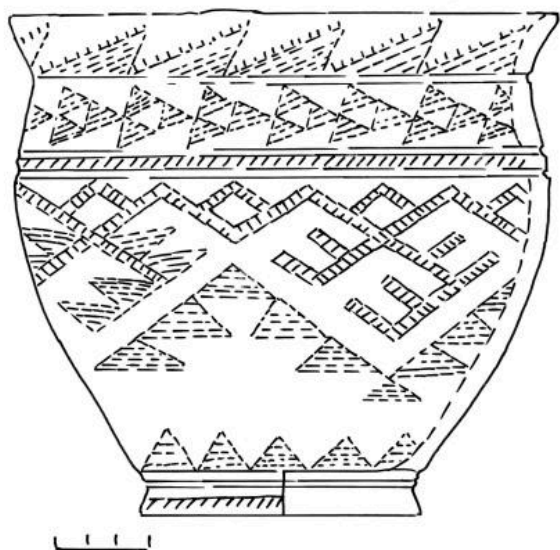
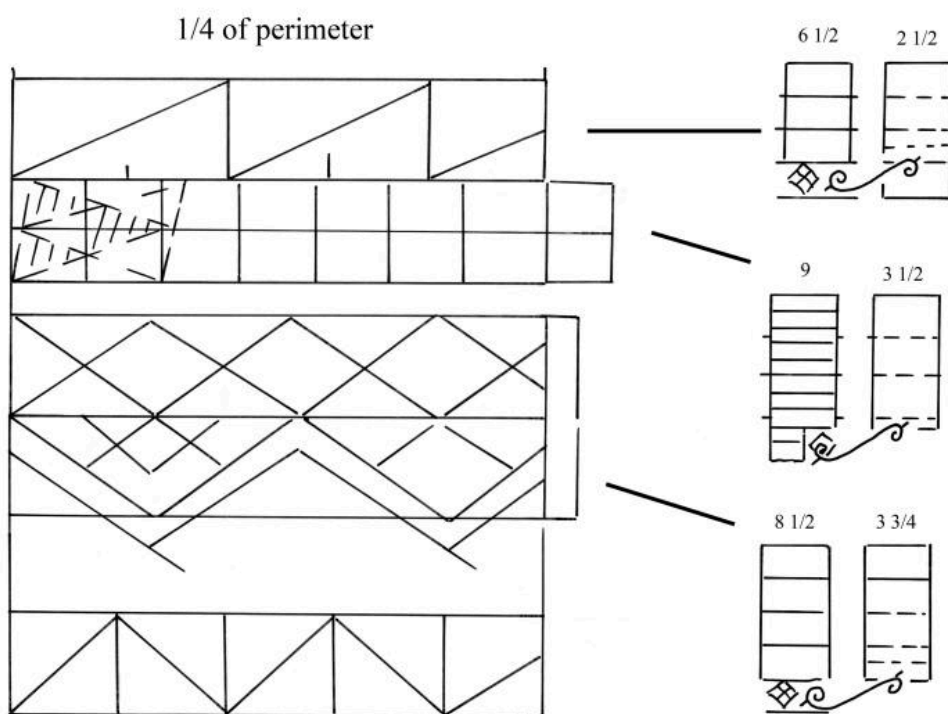

Figure 6. Application of spiral pattern for estimation of perimeter of horizontal section (original from: Кирюшин, Тишкин & Грушин 2000, fig. 2).

FIG 6. APPLICATION OF SPIRAL PATTERN FOR ESTIMATION OF PERIMETER OF HORIZONTAL SECTION (ORIGINAL FROM: SEE FIGURE).



a



b

Figure 7. Preliminary sketch of Andronovo ornamentation
(original from: Молодин 1985, fig. 46, 2).

FIG 7. PRELIMINARY SKETCH OF ANDRONOVO ORNAMENTATION (ORIGINAL FROM: SEE IMAGE).

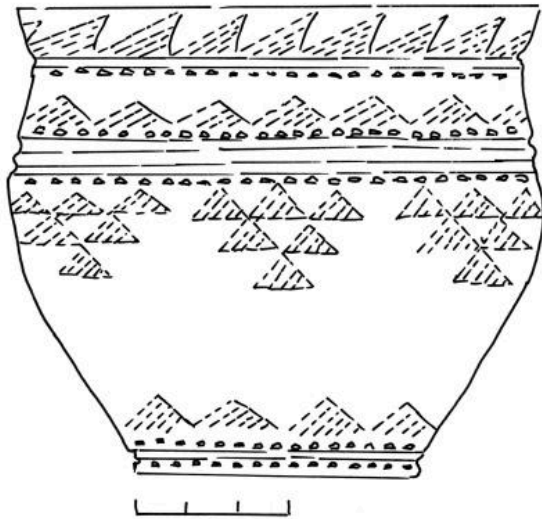

a

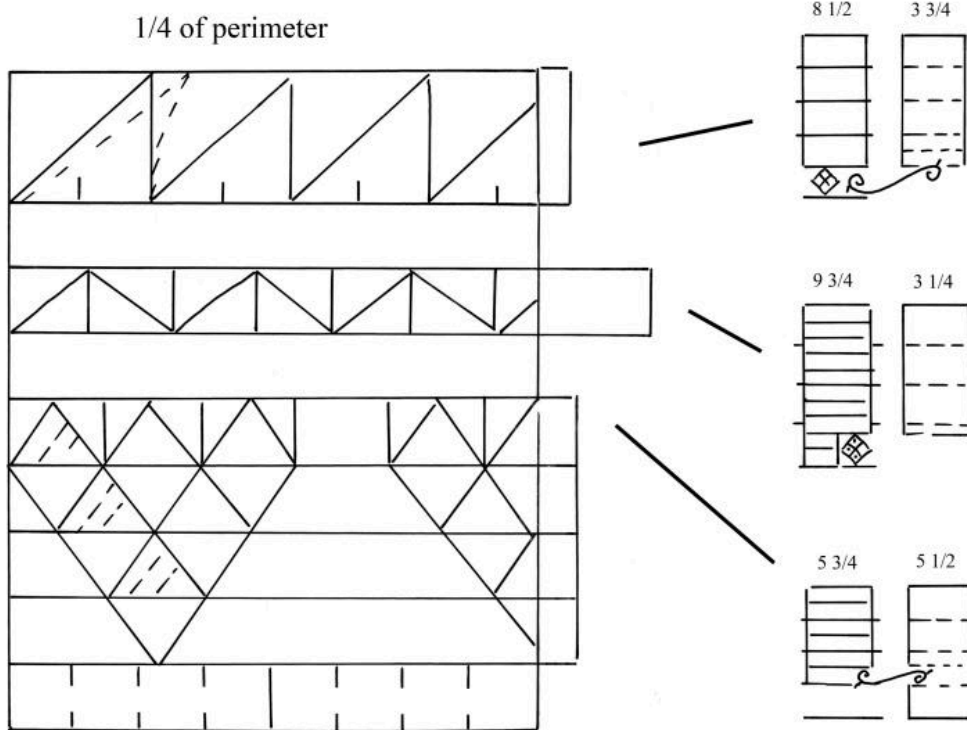

b

Figure 8. Preliminary sketch of Andronovo ornamentation
(original from: Бобров & Михайлов 1989, fig.19, 2).

FIG 8. PRELIMINARY SKETCH OF ANDRONOVO ORNAMENTATION (ORIGINAL FROM: SEE IMAGE).



Figure 9. Samples of the Andronovo culture pottery
(from: <http://public.edu.asu.ru>, retrieved 01/05/2017)

FIG 9. SAMPLES OF THE ANDRONOVO CULTURE POTTERY (FROM: [HTTP://PUBLIC.EDU.ASU.RU](http://PUBLIC.EDU.ASU.RU))

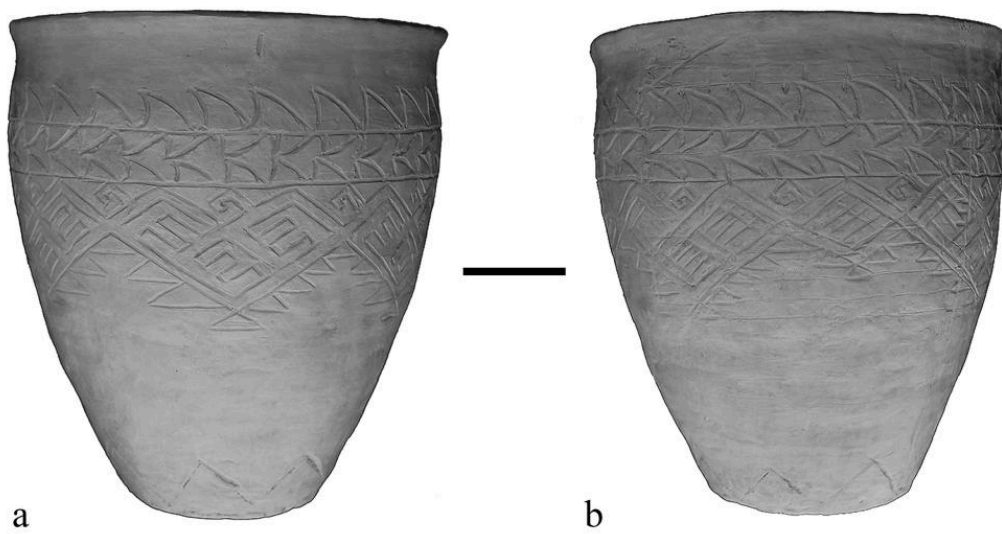

Figure 10. Experimental reconstruction of Andronovo ceramic geometric design.

FIG 10. EXPERIMENTAL RECONSTRUCTION OF ANDRONOVO CERAMIC GEOMETRIC DESIGN.